

Three pass flame tube boiler

Steam Capacity: 2000-6000 kg/h

Three pass flame tube boiler

Steam capacity: 2000-6000 kg/h

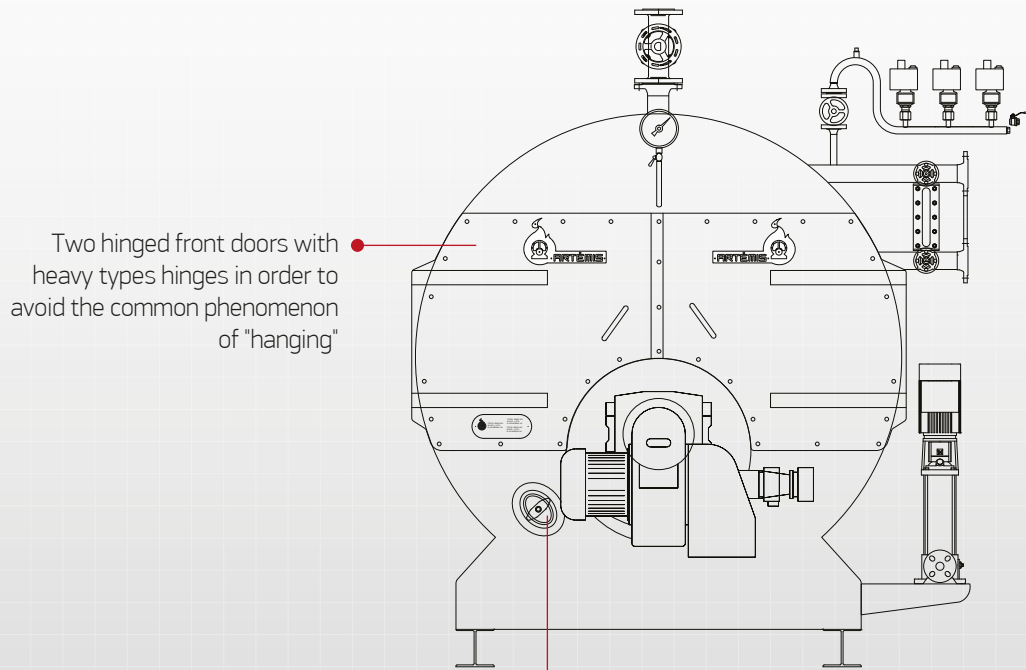

Two hinged front doors with heavy types hinges in order to avoid the common phenomenon of "hanging"

Large inspection handhole. The position ensures an easy and thorough inspection of the inside of the boiler

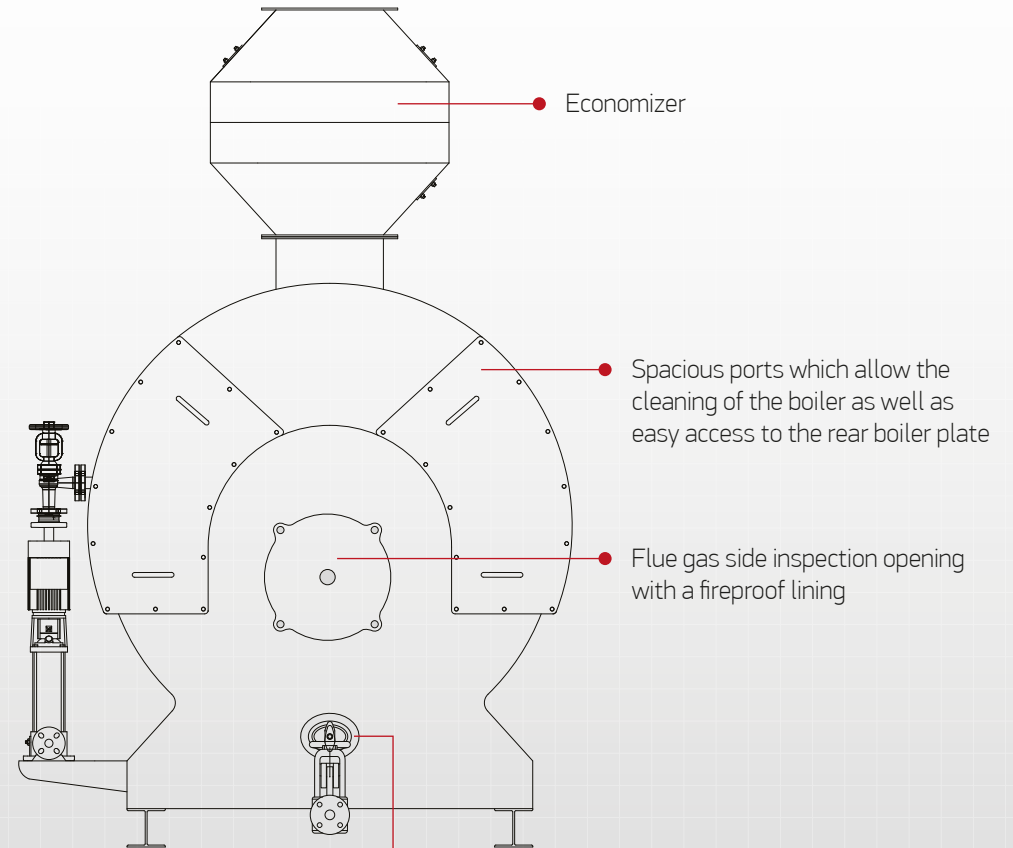

Economizer

Spacious ports which allow the cleaning of the boiler as well as easy access to the rear boiler plate

Flue gas side inspection opening with a fireproof lining

Large inspection handhole. The position ensures an easy and thorough inspection of the inside of the boiler

Three pass flame tube boiler

Steam capacity: 2000-6000 kg/h

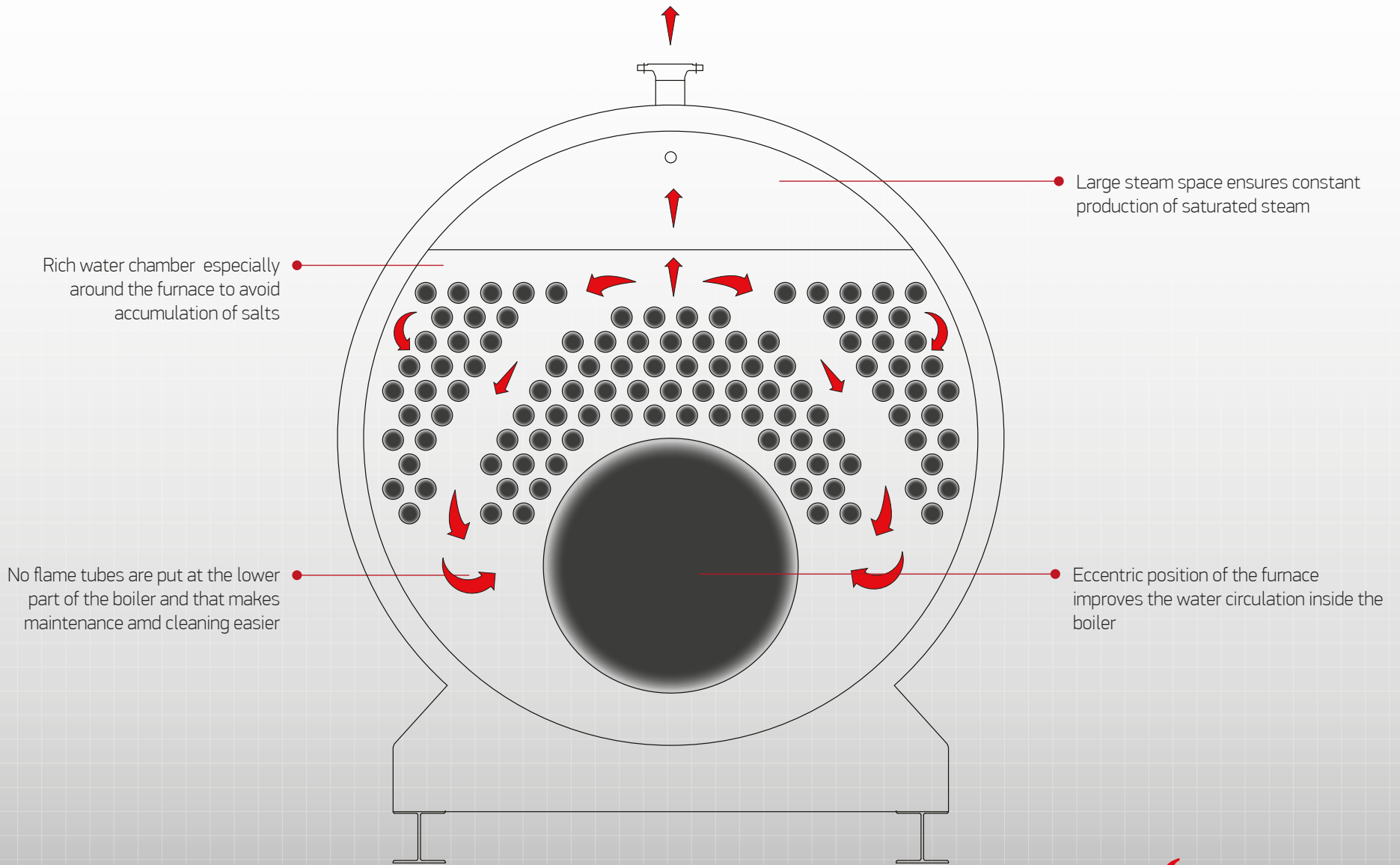

Three pass flame tube boiler

Steam capacity: 2000-6000 kg/h

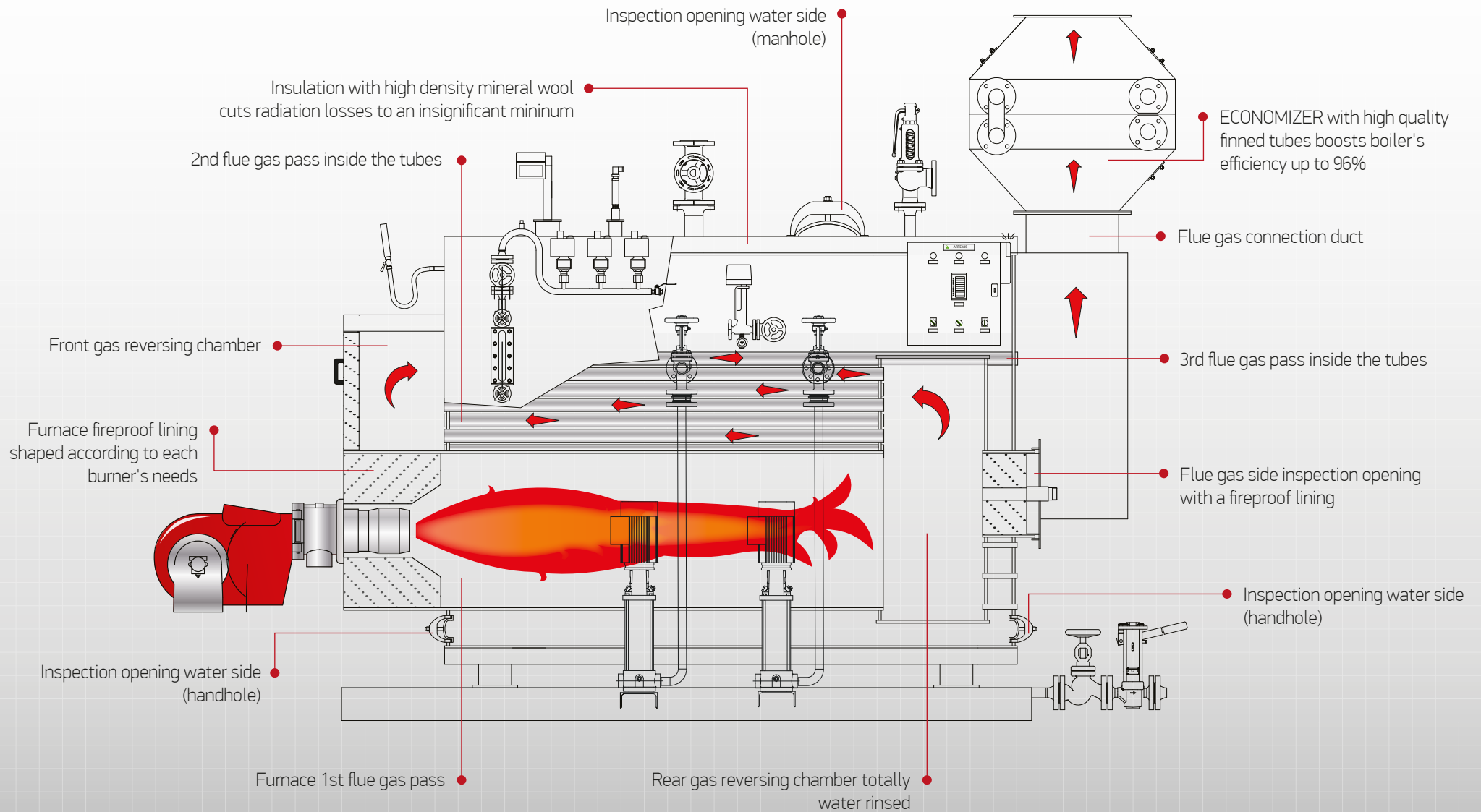

Three pass flame tube boiler

Steam capacity: 2000-6000 kg/h

